

SPRINGLOADED BACKPRESSURE REGULATOR LBS4

HIGH ACCURACY • ANALYZER APPLICATIONS



MAIN FEATURES

- ss 316L throughout
- diaphragm (large) sensing
- bubble tight shut-off
- 3 pressure ranges
- viton/ptfe seals, ptfе coated diaphragm
- bottom mounting and panel mounting
- shell design according to EN 12516

CHARACTERISTICS

Max. pressure	: 35 bar
Set pressure range	: 0 – 20 bar
Seat diameter	: 8 mm
Cv (Kv)	: 1.3 (1.1)
Materials:	
• Body & Trim	: ss 316L
• Spring housing	: ss 316L
• Seat insert	: elastomer
• Diaphragm	: ptfе/butyl, ss 316L
• Seals	: elastomer
Connections:	
• Line	: ½" npt
• Gauge ports	: 2x ¼" npt
Weight	: 2,6 kg
Temperature range	: -20 to +80°C*

CLEANING

This regulator is ultrasonically cleaned and degreased. Cleaning based on ASTM-G93 Level C / CGA 4.1 is optional.

PORTING STYLE

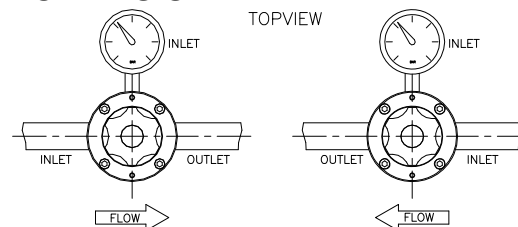

This is not a safety valve!

* Actual range depends on choice of seat- and seal material.

PANELMOUNTING HOLES:
 - 2X $\phi 5,5$, FOR M5X20 SCREWS
 - 1X $\phi 61$, FOR REGULATOR

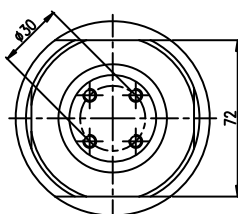
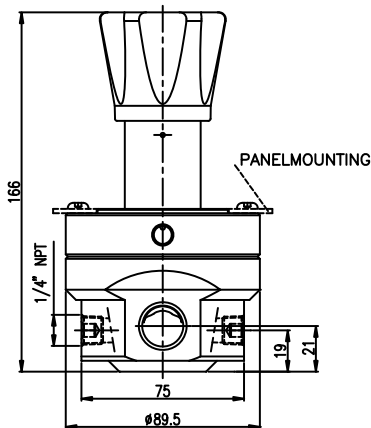
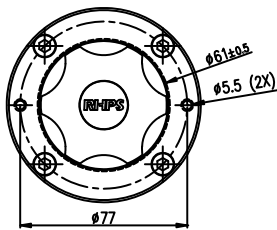

BOTTOMMOUNTING HOLES
 4X $\phi 6$, 10MM THREAD

⚠ Swagelok regulators are not "Safety Accessories" as defined in the Pressure Equipment Directive 97/23/EC:

⚠ Do not use the regulator as a shut off device.

RHPS Series

Swagelok

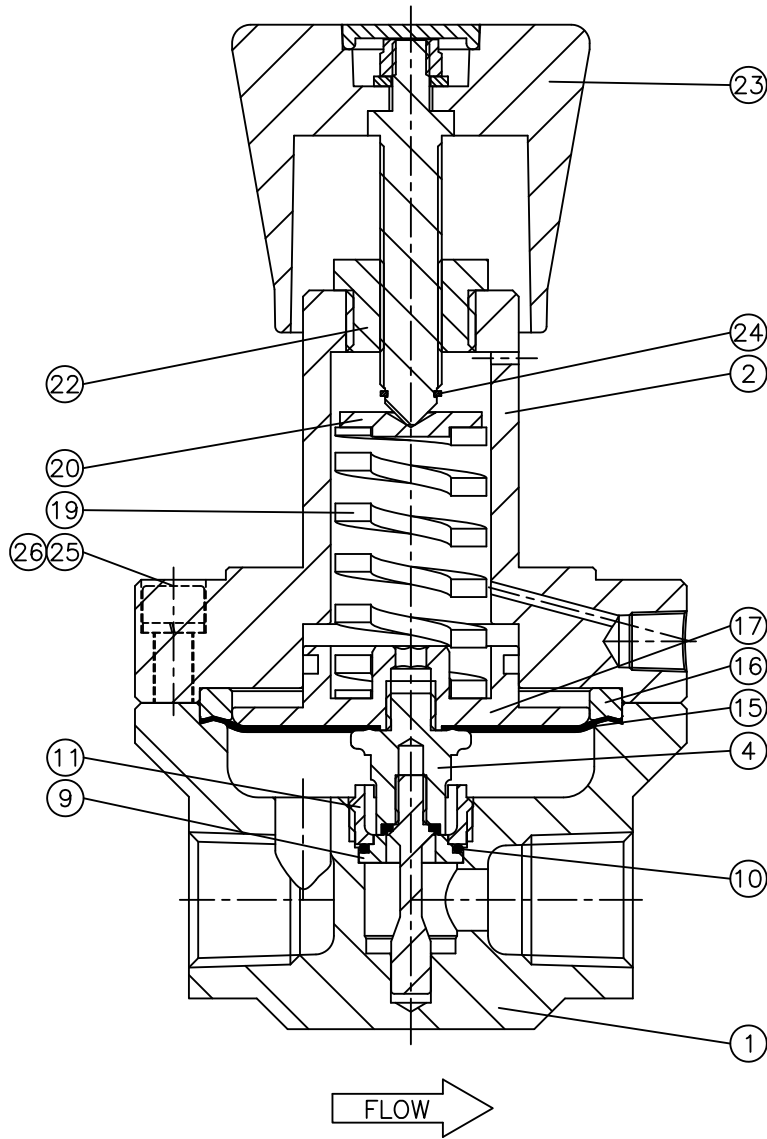

ORDERING INFORMATION

example: LBSN4-02-2-TTV

LBS	N4	- 02	- 2	- T	T	V
series / inlet	connection	material	Set pressure range	o-rings	diaphragm	seat
LBS=35 bar	N4= ½" npt	02= ss316L	1 = 0-3 bar 2 = 0-9 bar 3 = 0-20 bar	T= ptfe	T= ptfe Option: M= ss316L (0-3 or 0-9 bar only)	V= viton Option: F= ffkm

Red text identifies an example ordering number

Safe Product Selection

When selecting a product, the total system design must be considered to ensure safe, trouble-free performance. Function, material compatibility, adequate ratings, proper installation, operation, and maintenance are the responsibilities of the system designer and user.

RHPS, Swagelok—TM Swagelok Company
 © 2010 Swagelok Company
 Printed in U.S.A., OM
 June 2010, R0
 MS-02-403-E

FLOWCURVES (standard diaphragm)

Flowcurves LBS4-02-1

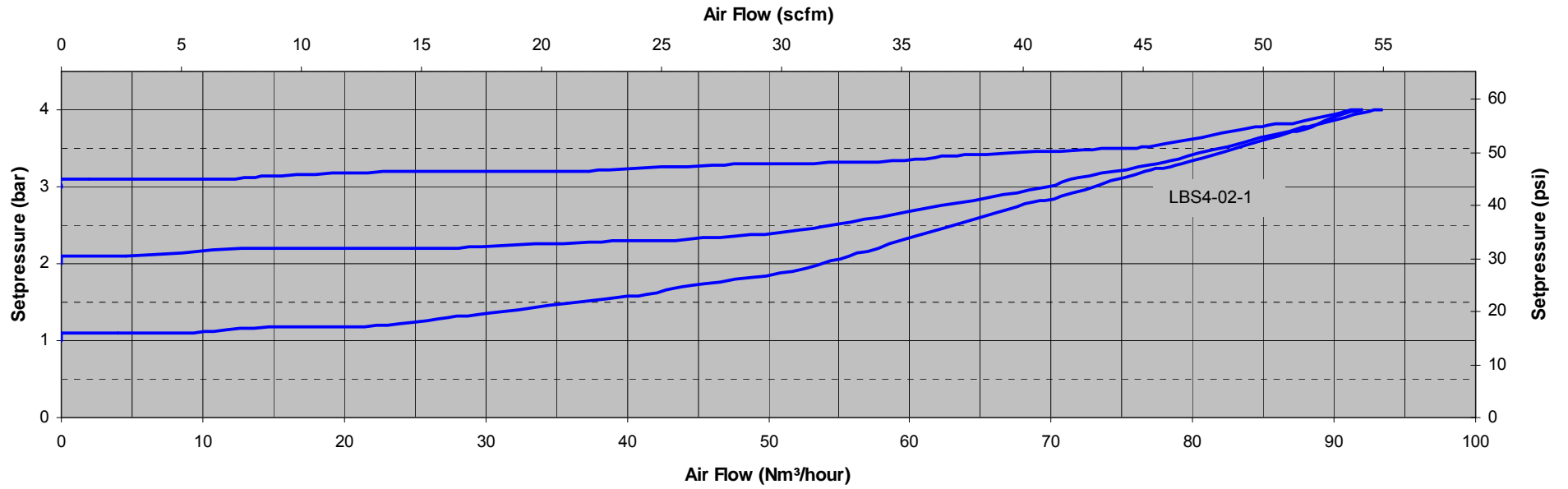

Flowcurves LBS4-02-2 and LBS4-02-3

