

## AIRLOADED RATIO PRESSURE REGULATOR

### SELF VENTING • REMOTE CONTROL • HIGH PRESSURE



A ratio regulator is a dome loaded pressure regulator. The pilot pressure is usually a 0 - 6 bar signal. Whereas in a true dome loaded regulator the ratio between pilot (=dome) pressure and outlet pressure is 1:1, the ratio in this regulator can be almost anything.

#### MAIN FEATURES

- ss 316L
- balanced valve
- Cv 1.95
- diaphragm or piston sensing
- bubble tight shut-off
- self-venting
- shell design according to EN 12516

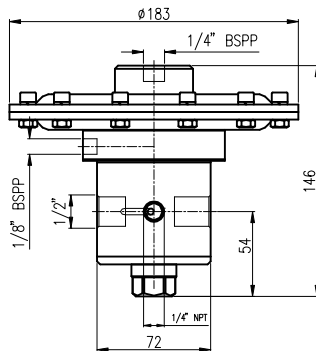

RA4

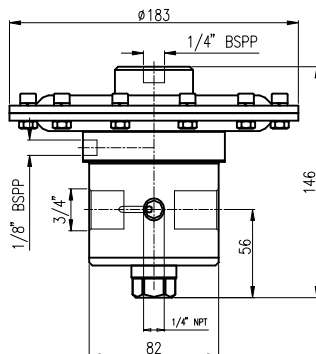

RA6

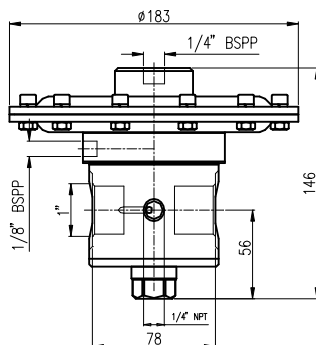

RA8

#### CHARACTERISTICS

Inlet pressure	: 400 bar
Outlet range	: 0 - 400 bar
Pilot pressure	: 0 - 10 bar
Ratios	: 15, 40, 70
Seat diameter	: 10 mm
Relief valve	: 4 mm
Cv ( Kv )	: 1.95 (1.66)
Materials:	
• Body & Trim	: ss 316L
• Springhousing	: ss 316L
• Seat insert	: pctfe
• Seals & Diaphragm	: elastomer
Connections:	
• Line	: bspp, npt (RA8 only bspp) flanges to DIN / ANSI B16.5
• Dome	: 1/4" bspp
• Vent	: 1/8" bspp
• Gauge port	: 1/4" npt
Weight RA4 / RA6	: 5.7 kg / 6.2 kg (without flanges)
Temperature range	: -20 to +80°C *

#### PNEUMATIC ACTUATION

- By springloaded regulator or proportional regulator.

#### OPTIONS

- Larger sizes available on request with specific ratio's.

#### CLEANING

This regulator is ultrasonically cleaned and degreased. Cleaning based on ASTM-G93 Level C / CGA 4.1 is optional.

**Do not use teflon tape or anaerobic sealing compounds on the bspp threads.**

\* Actual range depends on choice of seat- and seal material.



Swagelok regulators are not "Safety Accessories" as defined in the Pressure Equipment Directive 97/23/EC:



Do not use the regulator as a shut off device.

**RHPS Series**

**Swagelok**

